

# Vibration measurements on small to medium single-span railway bridges

*C. Rebelo*

*Civil Engineering Department, University of Coimbra, Portugal*

*L. Simões da Silva*

*Civil Engineering Department, University of Coimbra, Portugal*

*M. Pircher*

*Centre for Construction Technology & Research, University of Western Sydney, Australia*

*C. Rigueiro*

*Civil Engineering Department, Polytechnic Institute of Castelo Branco, Portugal*

*M. Heiden*

*TDV – Graz, Austria*

**ABSTRACT:** Due to the need for increasing train speeds several existing small to medium span bridges in the track Linz-Wels (Austria) were re-evaluated. In a preliminary numerical calculation, considering conservative values for the dynamic parameters, very high vertical accelerations were computed for some of those structures. An experimental program was thus carried out in order to get a better estimation for the dynamic behaviour of the bridges, concerning mainly the first vertical eigenfrequency and the corresponding viscous damping. The paper reports on the results of this experimental investigation and identifies some areas where further research is necessary.

## 1 INTRODUCTION

The dynamic behaviour of small to medium span railway bridges for high speed traffic is still difficult to foresee during the design, since the influence of the non-structural environment and of the super-structure composed by rails, sleepers and ballast is not well known. This conditions the practical use of the norms, namely the eurocode 1 part 2, not only for the design of new structures but especially when existing bridges must be checked for increasing traffic speeds [1,3].

A number of such bridges in the track between Linz and Wels in Austria had to be reevaluated [6] in order to permit the increase of train speeds up to 200km/h in accordance with guidelines shown in the ERRI report [2]. In a preliminary numerical evaluation very high vertical accelerations were computed for those structures using the software system RM2000, showing the need for better estimates of the natural frequencies and viscous damping. Resonance under train speeds between 200km/h and 240km/h led to maximum accelerations of up to 20 m/s<sup>2</sup> in some cases.

An experimental program was therefore implemented, which included the measurement of the vertical accelerations at up to eight points under the bridge decks during normal railway operation and its modal identification based on those measurements. Two to four hours of continuous data recording, depending on the structure under consideration, was considered to be sufficient for the dynamic identification. This included a number of at least ten train passages, which were considered to be the most important source of excitation for the modal identification.

In this way the first natural frequency and the corresponding modal damping could be estimated for all structures. For the more flexible structures, with longer spans, higher natural frequencies, mode shapes and damping could be obtained as well. In some cases measurements of

the accelerations on the rails and in the ballast were also carried on, although those results are not presented here.

## 2 DESCRIPTION OF THE BRIDGES

### 2.1 Reinforced concrete frames

A set of four monolithic reinforced concrete frames with spans varying from 2.5 to 5.0 meters were measured. The corresponding geometrical characteristics are shown in Table 1 and Fig. 1. Bridge 2 is the only one of the ‘box’ type and is composed by two twin boxes laying side by side, one for each direction of railway traffic. The other bridges are of the ‘frame’ type and are composed by only one monolithic structure for both railway tracks.

Table 1 – Geometrical characteristics of the reinforced concrete frames according to the structural layout

Bridge	Span L [m]	Width B [m]	Thickness dRF [m]	Thickness dRR [m]	Thickness dS [m]	Structural Type
2	2.50	2x4.25	0.18	0.18	0.18	<i>box</i>
4	2.50	9.30	0.30	0.25	0.25	<i>frame</i>
5	5.00	9.0	0.40	0.38	0.40	<i>frame</i>
10	5.00	9.0	0.32	0.32	0.32	<i>frame</i>

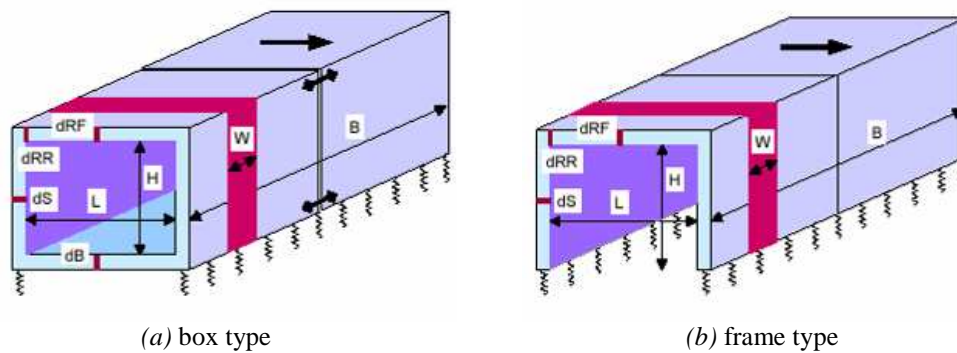

Figure 1 – Structural layout of small span bridges

### 2.2 Single-span slabs

Another set of six bridges with spans varying from 5.75 meters to 23.5 meters have the common characteristic of being composed of single-span simple supported twin slabs, laying side by side, one for each track. The geometric characteristics are summarized in Fig. 2 and in Table 2.

The ballast depth has an average of 0.60 m, varying between 0.55 m and 0.65 m depending on the slab thickness, and spans over the entire width of the twin decks.

The structural layout of the prestressed concrete decks (Bridges 1, 3, 8 and 12) corresponds to one-span simply supported slab with slightly variable depth. In the case of Bridge 7 the simply supported slab is made of HEB360 steel bars filled with concrete. Bridge 11 is also simply supported and made of reinforced concrete.

The support conditions, although defined generally as simple supports, are of two types. In bridges 1, 3, 8 and 12, the bearing supports, two at each extremity of the deck, are made of steel pots filled with rubber material and can be considered free to rotate. For the other structures no specific apparatus have been used and the slab lies directly on the top of the abutment.

There is no continuity of the slab over the supports to the abutments, except the one materialized by the superstructure composed of ballast, sleepers and rails. It is also to emphasize the fact that in bridges 1, 3 and 8 the line of supports is not collinear when considering both decks, as illustrated in Figure 2-b, and that the line of supports in Bridge 12 is skew relatively to the axis of the bridge.

Table 2 – Geometrical characteristics of the slab-type bridges

Bridge	Span [m]	Width [m]	HL [m]	H [m]	HR [m]	$\alpha$ [°]	Type
1	23.50	5.14	0.92	1.14	0.91	90°	Prestressed
3	19.50	6.49	0.97	1.10	0.84	90°	Prestressed
7	9.00	4.52	0.43	0.43	0.43	90°	Mixed
8	21.00	4.23	1.05	1.15	1.05	90°	Prestressed
11	5.75	4.44	0.40	0.40	0.40	90°	Reinforced
12	11.44	4.54	0.7	0.90	0.70	63.9°	Prestressed

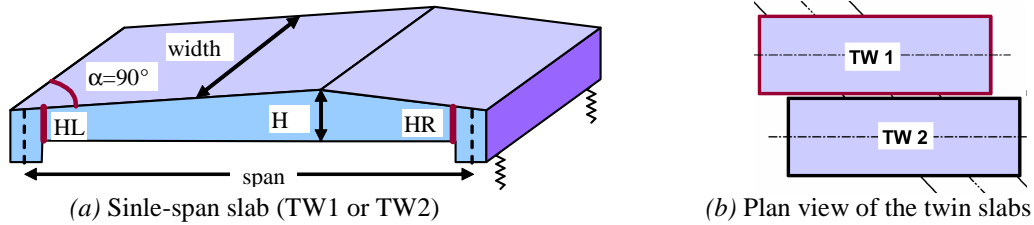

Figure 2 – Structural layout of generic medium span bridges

### 3 MEASUREMENT PROCEDURES

#### 3.1 Measurement layout

The main concern of the measurements was to identify the first eigenfrequency for which the respective eigenmode is characterized mainly by vertical deflections of the deck. Although for the slab-type bridges this corresponds to the lowest frequency, it would not be the same for the frame-type bridges, as it was already evidenced in the numerical models.

In that sense, for the frame structures, the vertical accelerations along the middle span line (Fig. 3-a) and the horizontal acceleration at about middle height of the vertical slabs were measured. For the slab type structures, according to the expected eigenforms and to the symmetry conditions, only one half-side of each deck was instrumented (Fig. 3-b). Although a maximum of eight channels were available only a number of them were used to capture the vertical accelerations of the deck at mid-span and at  $\frac{1}{4}$  of the span (see Fig. 3-b and Table 3). In this case the remaining sensors were used to measure accelerations on the rails, in the ballast and under the twin deck.

The response data was acquired using the Brüel & Kjær PULSE® multi analyser platform and recorded for post processing [4]. In addition, the type of train, number of carriages and velocity measured with a speedometer were manually recorded [8].

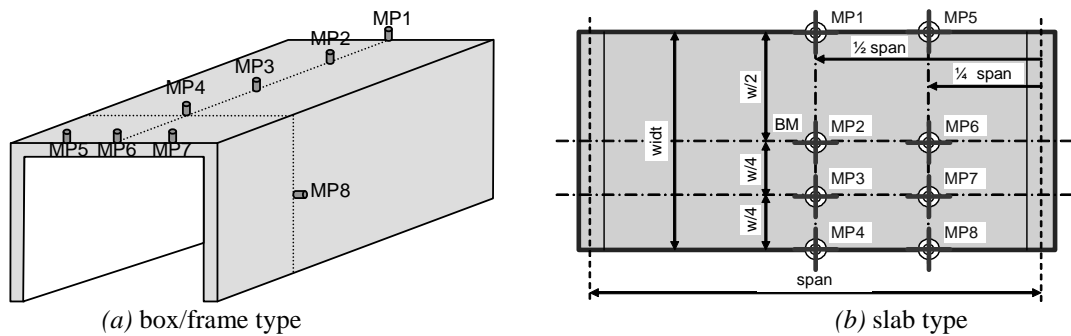

Figure 3 – General scheme of the measurement locations

Table 3 – Measurement points

Measurement Point	Structural Type									
	Slab						Frame			
	Bridge 1	Bridge 3	Bridge 7	Bridge 8	Bridge 11	Bridge 12	Bridge 2	Bridge 4	Bridge 5	Bridge 10
1	<i>n.a.</i>	●	<i>n.a.</i>	●	●	●	●	●	●	●
2	●	●	●	●	●	●	<i>n.a.</i>	●	●	●
3	<i>n.a.</i>	●	<i>n.a.</i>	●	<i>n.a.</i>	<i>n.a.</i>	●	●	●	●
4	●	●	●	●	●	●	<i>n.a.</i>	●	●	●
5	●	●	<i>n.a.</i>	●	●	<i>n.a.</i>	●	●	●	●
6	●	●	●	●	●	●	●	●	●	●
7	<i>n.a.</i>	●	<i>n.a.</i>	<i>n.a.</i>	<i>n.a.</i>	<i>n.a.</i>	●	●	●	●
8	●	●	<i>n.a.</i>	●	●	<i>n.a.</i>	●	●	●	●

● measured point      *n.a.* non measured point

### 3.2 Identification methods

Two methods were considered for the identification of eigenfrequencies, eigenforms and damping: (i) free vibration after train passages and (ii) natural ambient vibration between train passages. It was decided to capture and record the signal during enough time in order to obtain a significant number of at least ten train passages, corresponding to two to four hours of continuous signal recording.

The signal post processing consisted of two types of power spectra analyses. On the one hand the free vibration immediately after each train passage was collected for all trains and used to build the average spectra. Time histories with a fixed time length were considered, starting from the instant when each train leaves the bridge. Considering the longest eigenperiod expected for the structures, that time length should be enough for the free response to decay significantly.

Taking into account for each structure the entire sequence of all the time histories described above, it is possible to use a method for the parameter identification in the frequency domain such as the Peak Picking Method implemented in the software ARTeMIS<sup>®</sup>.

However, attention had to be paid to the effective time after which there is no more excitation on the bridge in order to prevent the distortion of the results and the erroneous identification of load harmonics. This was particularly sensitive in the case of the small span bridges, for which the free decay is quite short.

On the other hand, the ambient free vibration caused by unidentified natural excitation during the interval of train passages was collected and analyzed using the frequency domain decomposition method implemented in the referred software.

Although for the medium span bridges both procedures were able to identify the first natural frequency and damping, for the smaller bridges the measurement duration was not enough in order to allow for the natural ambient vibration to build significant spectral peaks. Besides that, the higher natural frequencies and modes could only be reliably identified for the medium span bridges.

As a complement, after the modal identification, selected measured responses during train passages were analyzed and compared with numerical results obtained for equivalent load sets crossing the bridge at about the same speed as it was registered for the respective train during the measurements (see [7,8]).

## 4 MEASUREMENT RESULTS

### 4.1 Free decay analysis

Examples of the modal identification in the frequency domain are show in Fig. 4 and the estimated values for the eigenfrequencies and damping ratios resulting are summarized in Table 4.

During the identification process it was noticed that both the natural frequencies and the damping ratio varied according to the amplitude of vibration, that is, for the same structure significantly different values were obtained if time shifts of up to 1,5 seconds were introduced in the starting point of the time histories, maintaining the same total time length, when comparing with the original time histories defined in the paragraph above. This effect is most probably due to non-linear effects provided mainly by the track, ballast and supports.

When the modal parameters obtained from the time shifted response histories are compared with those from the non-shifted histories two tendencies can be recognized: (i) the frequency increases and (ii) the damping factor decreases. These results are more evident in the lower modes and must be, therefore, related to the amplitudes of vibration. In fact the higher amplitudes in the lower modes mobilize mechanisms of energy dissipation related to friction in the supports and internal friction in the ballast in a stronger way than they are mobilized in the higher modes, for which the amplitudes of vibration are much lower. This also stresses the idea that the friction forces, probably mainly inside the ballast, become more important for lower amplitudes having an effect of increasing the overall stiffness of the structure. Again, this effect is less important for the higher modes.

Table 4 –Eigenfrequencies and damping considering non-shifted time series

Type	Bridge	Mode	Frequency [Hz]	Damping Ratio [%]	Mode type
Medium span slab	1	1 <sup>st</sup>	4.8	7.8	1 <sup>st</sup> Bending
		2 <sup>nd</sup>	13.3	4.9	2 <sup>nd</sup> Bending
		3 <sup>rd</sup>	16.9	2.0	1 <sup>st</sup> Torsion
		4 <sup>th</sup>	27.7	1.9	3 <sup>rd</sup> Bending
	3	1 <sup>st</sup>	6.4	9.3	1 <sup>st</sup> Bending
		2 <sup>nd</sup>	14.7	4.5	1 <sup>st</sup> Torsion
		3 <sup>rd</sup>	18.5	2.5	2 <sup>nd</sup> Bending
		4 <sup>th</sup>	33.7	2.8	3 <sup>rd</sup> Bending
	7	1 <sup>st</sup>	16.9	4.7	1 <sup>st</sup> Bending
		2 <sup>nd</sup>	25.5	0.9	1 <sup>st</sup> Torsion
		3 <sup>rd</sup>	49.0	0.7	2 <sup>nd</sup> Bending
	8	1 <sup>st</sup>	5.4	6.1	1 <sup>st</sup> Bending
		2 <sup>nd</sup>	18.8	2.8	2 <sup>nd</sup> Bending
		3 <sup>rd</sup>	19.2	1.8	1 <sup>st</sup> Torsion
		4 <sup>th</sup>	37.4	1.2	3 <sup>rd</sup> Bending
	11	1 <sup>st</sup>	15.0	2.0	1 <sup>st</sup> Bending
2 <sup>nd</sup>		36.4	1.4	1 <sup>st</sup> Torsion	
12	1 <sup>st</sup> -2 <sup>nd</sup>	13.7 – 16.5	7.7 – 4.7	Bending	
	3 <sup>rd</sup> -4 <sup>th</sup>	26.2 – 29.4	3.0 – 1.5	Torsion	
	5 <sup>th</sup> -6 <sup>th</sup>	41.4 – 43.6	2.1 – 2.2	Bending	
	7 <sup>th</sup> -8 <sup>th</sup>	50.7 – 51.8	0.2 – 0.2	Bending	
Small span frame	2	1 <sup>st</sup>	17.9	3.2	Main vertical deflection of the horizontal slab
	4	1 <sup>st</sup>	39.0	1.8	
	5	1 <sup>st</sup>	27.5	3.0	
	10	1 <sup>st</sup>	27.3	8.8	

The effect of coupling between both twin plates originated by the ballast was clearly identified in Bridge 12, which is skew. The influence of the interaction between the plates is shown in the duplication of the frequency peaks (Fig. 4) corresponding to symmetrical and non-symmetrical shapes with reference to the contact plan between the plates. This effect allows the quantification of the ballast shear stiffness since this depends only on the frequency gap between the peaks [5].

A consequence of this effect of coupling between the twin plates is the overestimation of the damping ratio when both frequency peaks are closer than the frequency resolution of the auto-spectra. This is probably the reason for the high first damping ratio measured in Bridges 1, 3

and 8 (see Table 4), whose line of bearing supports is not collinear (see Fig.2-b) inducing a skew type effect between the twin slabs.

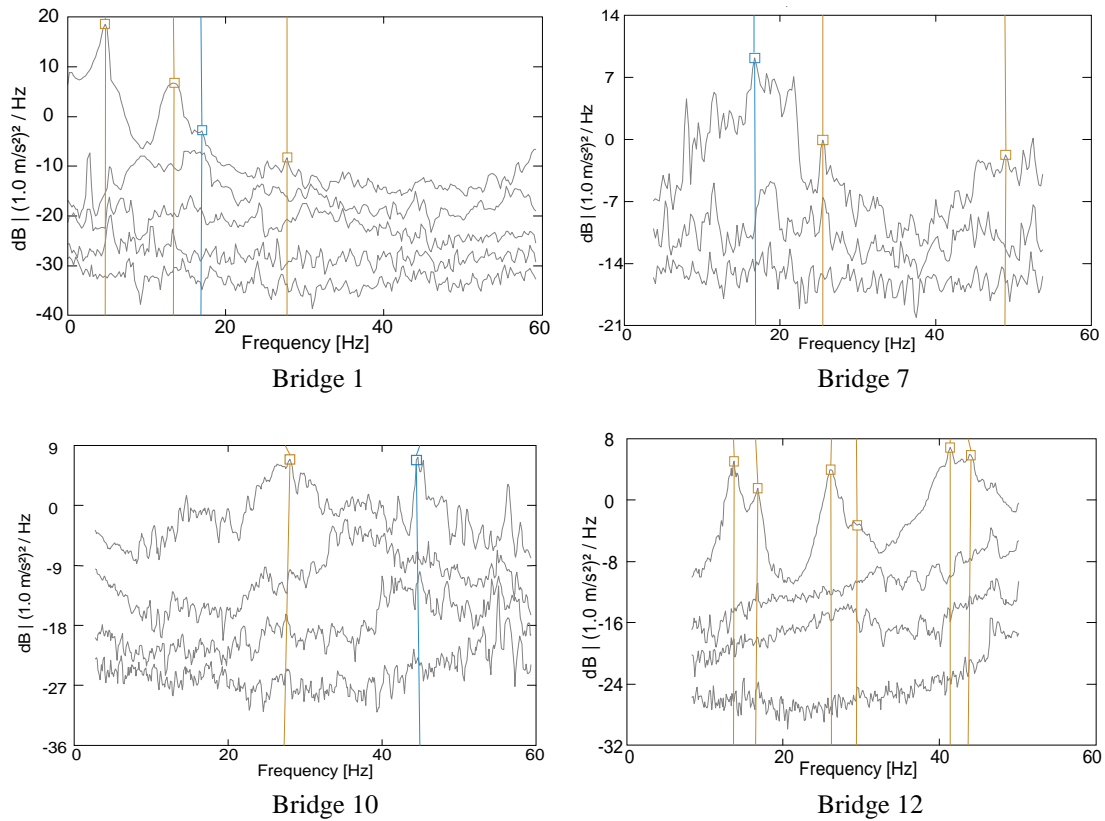

Figure 4 – Peak Picking method applied to bridges 1, 7, 10 and 12 (Frequency Domain Decomposition - Peak Picking; Average of the Normalized Singular Values of Spectral Density Matrices of all Data Sets)

#### 4.2 Ambient vibration

Ambient vibration methods are based on the assumption that all the dynamic excitation in the structure is of such a random type that all modes in the relevant frequency range are excited in the same way. Although this is not a typical problem for the application of such methods, the length of the time histories corresponding to the free vibration considered before can be extended for several minutes, depending on the railway traffic, so that the effect of the free vibration induced by the train passage is dimmed.

The results are summarized in Table 5. Because of the insufficient total measuring time and the fact that the maximum signal peak input had to be set up for the expected maximum acceleration during the train passages, conditioning the goodness of the signal for low amplitudes, the results are limited to the first natural frequency and to the longer span bridges.

Table 5 – Eigenfrequencies and damping for Bridges 1, 3, 8 using ambient vibration

Bridge	Mode	Frequency [Hz]	Damping Ratio [%]	Mode type
1	1 <sup>st</sup>	5.2	2.0	1 <sup>st</sup> Bending
3	1 <sup>st</sup>	8.6	1.9	1 <sup>st</sup> Bending
8	1 <sup>st</sup>	5.8	2.7	1 <sup>st</sup> Bending

Comparing these results with those given in Table 4, the difference is to be found in the damping ratio, resulting from the ambient vibration much lower damping values, and in the eigenfrequencies, which are higher than those given in Table 4. Both tendencies are in accordance with the explanation given above, concerning the probable influence of non-linear effects.

### 4.3 Response to train passages

The maximum acceleration measured during train passages is highly dependent on the frequency window used. Since the phenomenon under consideration is the risk of ballast desegregation in consequence of vibration, a frequency window of 0-25 Hz was used to investigate whether that limit was exceeded during the measurements.

For the dynamic structural identification the measured response to train passages is not of much use, unless a numerical structural model is fitted according to the identified modal characteristics and the numerical response to the real train is computed and compared with those measurements. This was done for several trains and bridges [7,8].

The comparison between the measured and the computed acceleration at the mid-span, shown in Fig. 5, concerns the passage of a locomotive over Bridge 1. Analysing the evolution of the time histories, it is obvious that, during the load application the initial part fits very well but the final part shows some differences. They are probably related to the interaction between train, superstructure and structure as shown e.g. in the UIC leaflet [10], which was not considered in the computations. With respect to the free vibration, the initial close correspondence between the two lines is lost because of a higher damping in the measured response than the one assumed in the computations, and because of the variation of the first natural frequency in the measured time series, as discussed above.

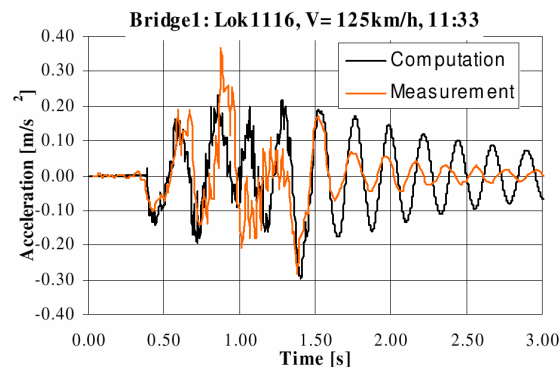

Figure 5 - Computed and measured response for Bridge 1.

## 5 CONCLUDING REMARKS

The main difficulty concerning dynamic measurements is usually the excitation. In the present case the vibration provided by the train passages could be used successfully. The resulting free vibration proved to be sufficient for the parameter identification methods to be applied.

The results show the existence of important non-linear effects, since the natural frequencies vary according to the amplitude of vibration, that is, growing amplitudes of the free vibration signal correspond to the decrease of the first natural frequency.

Damping factors are always difficult to be estimated exactly, since the sources for energy dissipation are various and different from the viscous type used in the theoretical formulation of the vibration problems. Particularly the damping due to friction between ballast particles and eventually the friction in the supports can play an important role in the type of structures under analysis. The tendency for the damping to increase with the vibration amplitude could be observed in the analysis. Also, the coupling effect between twin slabs developed through the ballast was clearly identified in the skew bridge and is most probably the responsible for the high measured damping ratios in the first eigenmode of bridges 1, 3 and 8.

The contribution of the ballast to the overall dynamic behaviour of this type of bridges is not yet well known. Since the problem of excessive accelerations in railway bridge results, in many cases, from a resonance situation in one of the lower natural frequencies, a better understanding of the damping mechanisms could be very useful for a more precise evaluation of the dynamic response during the design.

## ACKNOWLEDGEMENTS

The authors would like to thank Austrian Railway Authorities ÖBB for the technical support and the facilities needed for the measurement setup, as well as Eng. Helena Gervásio from GIPAC, Lisbon for the experimental support.

## REFERENCES

- [1] BUCKNALL, I. (2003) *New Eurocode Requirements for the Design of High Speed Railway Bridges*, IABSE Symposium, Antwerp
- [2] ERRI D 214/RP9 (1999) *Rail bridges for speeds over 200Km/h*, Final Report
- [3] prEN 1991- EUROCODE 1 – Part 2 (2002) *Traffic loads on bridges*, July 2002 (Conversion of ENV-1991-3 into 1991-2) (final draft)
- [4] Rebelo, C. & Gervásio, H. (2004) *Final report on the dynamic measurements and system identification of plate and frame railway bridges between Linz and Wels, Austria*, ACIV/GIPAC, Coimbra, Portugal
- [5] Rebelo, C. Rigueiro, C., Simões da Silva, L. (2005) *Modal Identification of Single-span Railway Viaducts*, 1<sup>st</sup> International Modal Analysis Conference - IOMAC, April 26-27, Copenhagen
- [6] Rebelo, C. *et al.* (2005) *Vibration measurements on existing single-span concrete railway viaducts in Austria*, EUROLYN, 4-7 September, Paris
- [7] Rigueiro, C. *et al.* (2005) *Comportamento dinâmico de pontes ferroviárias com plataforma balastrada*, Congreso de Métodos Numéricos en Ingeniería, 4 a 7 de Julio, Granada
- [8] TDV-Austria (2004) *Final Report of the Rolling Stock Investigations of Plate & Frame Bridges between Linz and Wels*, May 2004, Austria
- [9] TDV. 2004. *RM2004 – Software & Technical Description*, Graz, Austria
- [10] UIC leaflet: UIC 776-2R(2002) *Design requirements for rail-bridges based on interaction phenomena between train, track, bridge and in particular speed*. (July 2002)
- [11] Zacher, M. (2000) *Dynamic of Railway Bridges*, 5th ADAMS/Rail Users' Conference Haarlem, The Netherlands